

PIN: 11-16-100-001
Sale Date: 06/23/09
Sale Price: \$169,000
Acres: 8.11 Net
Classification: Rural Residential

11-16-100-001

8580.50

R-Res



11-16-100-901

B.L.L #8580.75

AG



95

#7
Lean-To

95

06

06

95

95

06

LEGAL DESCRIPTION:	CLASS:	-----	CSR'S	.00	-----	CODE	VALUE	ACRES
16-91-36	R RESIDENTIAL	GROSS	10.00	CURRENT				
A.C.T. GRANT		ROADS	1.89	LAND	28,500			
10 A N OF CREEK NW NW		D.D.		BLDG				
		R.R.		DWLG	158,790(1)			
		MISC						
				TOTAL	187,290			
		NET	8.11					

-----		-----		-----		-----		-----	
		YEAR	2009						
		LAND	28,500	ROAD				1.89	
		BLDG							
		DWLG	158,790(1)						
		TOTAL	187,290						
		NET TX							

DEED HOLDER:	DATE REFER	CONTRACT HOLDER:	DATE REFER	YEAR	2008	YEAR	2008	YEAR	2008
RICHARDSON MATTHEW D	07092009 1			LAND	28,590	ROAD			1.89
RICHARDSON MEGAN M				BLDG					
1526 560TH ST				DWLG	151,360(1)				
STORM LAKE IA 50588				TOTAL	179,950				
				NET TX					

-----	-----	-----	-----	-----	-----	-----	-----	-----	-----
TERRY STEVEN L	08232005 6			YEAR	2007				
TERRY JENNIFER E				LAND	28,590	ROAD			1.89
1526 560TH ST				BLDG					
STORM LAKE IA 50588				DWLG	151,360(1)				
				TOTAL	179,950				
				NET TX					

-----	-----	-----	-----	-----	-----	-----	-----	-----	-----
KOSKY ANDREW W	07282003 5			YEAR	2007				
1526 560TH ST				LAND	24,230	ROAD			1.89
STORM LAKE IA 50588				BLDG					
				DWLG	128,270(1)				
				TOTAL	152,500				
				NET TX					

-----	-----	-----	-----	-----	-----	-----	-----	-----	-----
EHLER TIMOTHY T	4			YEAR	2006				
1526 560TH ST				LAND	24,230	ROAD			1.89
STORM LAKE IA				BLDG					
				DWLG	117,250(1)				
				TOTAL	141,480				
				NET TX					

REMARKS:	-----	-----	-----	-----	-----	-----	-----	-----	-----
1 W.D. #091970 06-23-09 \$169,000 (D000)				YEAR	2005				
4 W.D. #022959 08-23-02 \$139,000(D000)				LAND	24,230	ROAD			1.89
5 W.D. #033085 07-02-03 \$135,000 (D000)				BLDG					
6 W.D. #052560 08-03-05 \$145,000 (D000)				DWLG	120,430(1)				
				TOTAL	144,660				
				NET TX					

-----	-----	-----	-----	-----	-----	-----	-----	-----	-----
				YEAR	2006				
				LAND	24,230	ROAD			1.89
				BLDG					
				DWLG	117,250(1)				
				TOTAL	141,480				
				NET TX					

Res. Structure		Finish				Plumbing		Addition		Garage	
Occ. Code	101	Ttl Rooms Above #	8	Bedrooms Above #	4	Full Bath	2	Addition	1 of 3	Garage	No garages
Occ. Descr.	Single-Family / Owner Occupied	Ttl Rooms Below #	0	Bedrooms Below #	0	Shower Stall Bath		Year Built	2006	Style	
Year Built	1920	Bsmt Fin Area #1				Toilet Room	1	EFA	3	W X L	
EFA / EFYr	89 / 1920	Bsmt Fin Area #2				Lavatory	1	EFA Year	2006	Area (SF)	
Arch. Dsgn	N/A	Bsmt Fin Area #3				Water Closet		Style	1 Sty Frm	Year Built	
Style	2 Story Frame	Foundation	C Blk			Sink	1	Area (SF)	320	EFA	
AreaSF/TLA	1,020 / 2,670	Exterior Walls	Vinyl			Shower Stall/Tub		Condition	Normal	EFF Year	
Condition	V Good	Roof	Asph / Hip			Mtl St Sh Bath		Bsmt (SF)		Condition	
Basement	Full	Interior Finish	Plas			Mtl Stall Shower		NoBsmt Flr(SF)		Bsmt (SF)	
No Bsmt Flr.	0	Flooring	Carp / Vinyl / Hdwd			No Bathroom		Heat	FHA - Gas	Qtrs Over	
Heat	FHA - Gas	Non-base Heating		Fireplace		Wet Bar		AC	Yes	Qtrs Over (SF)	
AC	Yes	Floor/Wall #	0			Whirlpool Bathroom		Attic (SF)		Qtrs AC (SF)	
Attic	None	Pipeless #	0			Whirlpool Tub		See other pages for more additions.			
		Hand Fired (Y/N)	No			No Hot Water Tank				Door Opnrs	
		Space Heat #	0			No Plumbing				Bsmt Stalls	
		Appliances				Sewer & Water Only					
		Range Unit	Built-In Vacuums			Water Only w/Sink					
		Oven - Single	Intercom System			Hot Tub					
		Oven - Double	BI Stereo			Bidet					
		Dishwasher				FbglS Service Sink					
		Microwave				Urinal					
		Trash Compactor				Sauna					
		Jennair				W'Pool Bath w/Shower					
		Security System				Water Only					
						No Tub/Shower					



Bldg / Addn	Description	Units	Year					
1 of 1	101 — Single-Family / Owner Occupied							
	2 Story Frame	1,020						
	Base Heat: FHA - Gas							
	Add Central Air	1,020						
#1	Porch: 1S Frame Enclosed	208 SF						
#2	Porch: 1S Frame Open	140 SF						
	Deck #1: Concrete Patio-Med	267 SF						
	Deck #2: Wood Deck-Med	320 SF						
	Plumbing	5						
1 of 3 Adtn	1 Story Frame	320 SF	2006					
2 of 3 Adtn	1 Story Frame	84 SF	1920					
3 of 3 Adtn	1 Story Frame	226 SF	2001					

	Count	Ag Building Description	Units		Year					
1 of 2 P:6	1	MTL POLE 925-Steel Utility Bldg	52' X 100'	5,200 SF	1979					
2 of 2 P:7	1	MTL ROOF (OPEN ALL SIDES) 908-Lean-To	10' X 40'	400 SF	2006					

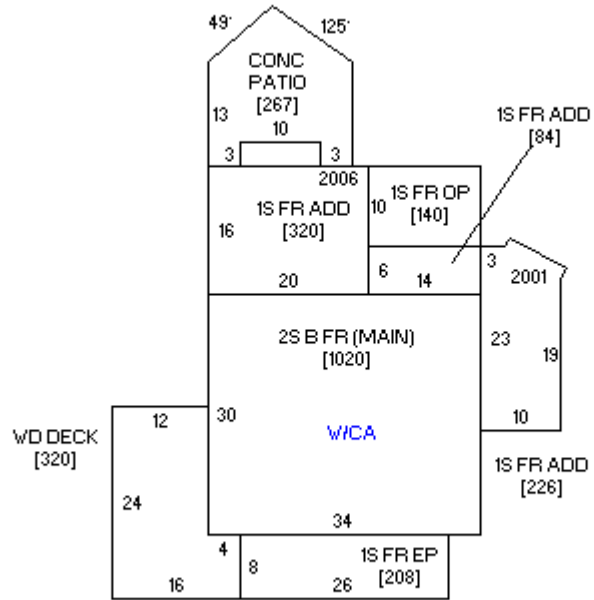



08/27/2008



03/11/2005



11/08/2001