

PIN: 03-18-200-001

Sale Date: 06/26/09

Sale Price: \$35,000

Acres: 4.32 Net

Classification: Rural Residential

03-18-200-001

#9093.50

R-Res

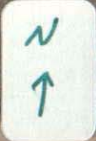

LEGAL DESCRIPTION:	CLASS:	-----	CSR'S	.00	-----	CODE	VALUE	ACRES
18-93-36	R RESIDENTIAL		GROSS	4.71	CURRENT			
S.R.-REMB. LEE			ROADS	.39	LAND	19,250		
PT NW NE			D.D.		BLDG			
			R.R.		DWLG	23,190( 1)		
			MISC					
					TOTAL	42,440		
			NET	4.32				

-----		=====		=====		=====	
		YEAR	2009				
		LAND	19,250	ROAD			.39
		BLDG					
		DWLG	23,190( 1)				
		TOTAL	42,440				
		NET TX					

DEED HOLDER:	DATE REFER	CONTRACT HOLDER:	DATE REFER	YEAR	2008	-----	-----
TODD KERBY L	07092009 4			LAND	7,980	ROAD	.39
TODD LAURA L				BLDG			
1567 HWY 10				DWLG	26,680( 1)		
SIOUX RAPIDS IA 50585				TOTAL	34,660		
				NET TX			

-----	-----	-----	-----	YEAR	2007	-----	-----
HERMSTAD LINDA	12092003 3	..		LAND	7,980	ROAD	.39
1364 440TH ST				BLDG			
SIOUX RAPIDS IA 50585				DWLG	26,680( 1)		
				TOTAL	34,660		
				NET TX			

-----	-----	-----	-----	YEAR	2007	-----	-----
HERMSTAD TIMOTHY	01291998 2	.		LAND	6,760	ROAD	.39
HERMSTAD LINDA				BLDG			
1364 440TH ST				DWLG	22,610( 1)		
SIOUX RAPIDS IA				TOTAL	29,370		
				NET TX			

-----	-----	-----	-----	YEAR	2006	-----	-----
KLEAVELAND BROTHERS INC	1	HERMSTAD TIMOTHY	1	LAND	6,760	ROAD	.39
		HERMSTAD LINDA		BLDG			
		1364 440TH ST		DWLG	22,610( 1)		
		SIOUX RAPIDS IA		TOTAL	29,370		
				NET TX			

-----	-----	-----	-----	YEAR	2005	-----	-----
REMARKS:				LAND	6,760	ROAD	.39
1 CONT 142/761-62 06-23-90 \$12,000				BLDG			
2 W.D. #980198 06-23-90 (D022)				DWLG	22,610( 1)		
3 Q.C.D. #034501 10-02-03				TOTAL	29,370		
4 W.D. #091977 06-26-09 \$35,000 (D000)				NET TX			

-----	-----	-----	-----	YEAR	2005	-----	-----
				LAND	6,760	ROAD	.39
				BLDG			
				DWLG	22,610( 1)		
				TOTAL	29,370		
				NET TX			



Res. Structure		Finish				Plumbing		Addition		Garage	
Occ. Code	101	Ttl Rooms Above #	6	Bedrooms Above #	3	Full Bath	1	Addition	1 of 4	Garage	1 of 1
Occ. Descr.	Single-Family / Owner Occupied	Ttl Rooms Below #	0	Bedrooms Below #	0	Shower Stall Bath		Year Built	1900	Style	Det Frm
Year Built	1900	Bsmt Fin Area #1				Toilet Room		EFA	109	W X L	0' X 0'
EFA / EFYr	109 / 1900	Bsmt Fin Area #2				Lavatory		EFA Year	1900	Area (SF)	280
Arch. Dsgn	N/A	Bsmt Fin Area #3				Water Closet		Style	1 Sty Frm	Year Built	1910
Style	2 Story Frame	Foundation	Conc			Sink		Area (SF)	56	EFA	99
AreaSF/TLA	384 / 1,947	Exterior Walls	Wd Lap			Shower Stall/Tub		Condition	Very Poor	EFF Year	1910
Condition	V Poor	Roof	Asph / Gable			Mtl St Sh Bath					
Basement	1/2	Interior Finish	Plas			Mtl Stall Shower		Bsmt (SF)		Condition	V Poor
No Bsmt Flr.	0	Flooring	Carp / Hdwd			No Bathroom		NoBsmt Flr(SF)		Bsmt (SF)	
Heat	FHA - Gas	<b>Non-base Heating</b>		<b>Fireplace</b>		Wet Bar		Heat	FHA - Gas	Qtrs Over	None
AC	No	Floor/Wall #	0			Whirlpool Bathroom		AC	No	Qtrs Over (SF)	
Attic	None	Pipeless #	0			Whirlpool Tub		Attic (SF)		Qtrs AC (SF)	
		Hand Fired (Y/N)	No			No Hot Water Tank		See other pages for more additions.			
		Space Heat #	0			No Plumbing				Door Opnrs	
		<b>Appliances</b>				Sewer & Water Only				Bsmt Stalls	
		Range Unit	Built-In Vacuums			Water Only w/Sink					
		Oven - Single	Intercom System			Hot Tub					
		Oven - Double	BI Stereo			Bidet					
		Dishwasher				FbglS Service Sink					
		Microwave				Urinal					
		Trash Compactor				Sauna					
		Jennair				W'Pool Bath w/Shower					
		Security System				Water Only					
						No Tub/Shower					



Bldg / Addn	Description	Units	Year					
1 of 1	101 — Single-Family / Owner Occupied							
	2 Story Frame	384						
	Adjustment for basement - 1/2							
	Base Heat: FHA - Gas							
#1	Porch: 1S Frame Enclosed	110 SF						
#2	Porch: 1S Frame Enclosed	56 SF						
1 of 4 Adtn	1 Story Frame	56 SF	1900					
2 of 4 Adtn	1 1/2 Story Frame	256 SF	1900					
3 of 4 Adtn	1 Story Frame	280 SF	1900					
4 of 4 Adtn	1 1/2 Story Frame	240 SF	1900					
	Garage: Det Frame 0' X 0'	280 SF	1910					

	Count	Ag Building Description	Units		Year						
1 of 6 P:1	1	DBL OHB FR @ .90 926-Crib	29' X 40' 1,160 SF		1900						
2 of 6 P:2	1	L FR @ .90 906-Barn - Flat	31' X 40' 1,240 SF		1900						
3 of 6 P:3	1	SHED FR @ .40 908-Lean-To	16' X 40' 640 SF		1900						
4 of 6 P:4	1	HOG HSE FR @ .90 927-Shed	20' X 48' 960 SF		1900						
5 of 6 P:5	1	DBL FR @ .40 926-Crib	26' X 32' 832 SF		1900						
6 of 6 P:6	1	MACH FR @ .40 927-Shed	18' X 50' 900 SF		1900						

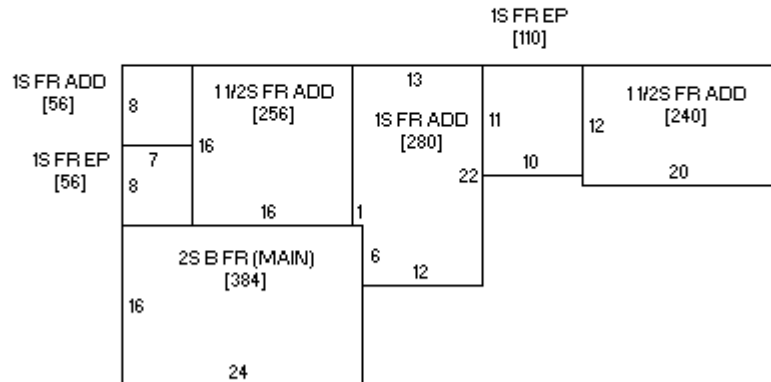
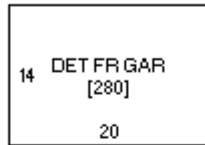



10/29/2008