

Pin: 03-11-200-012
Sale Date: 09/16/09
Sale Price: \$85,500
Acres: 4.62 Net
Classification: Rural Residential

03-11-200-012 #9063.75

R-Res



#3 MOVED
HERE



4

3



09

03-11-200-013 #9063.00

AG



LOCATION: 1774 430TH ST

DISTRICT: 00470 REF #:

PARCEL #: 03-11-200-012

ALT ID:

0000906375

LEGAL DESCRIPTION:

CLASS:

11-93-36
S.R.-REMB. LEE
LOT A IN N 1/2 NE 1/4

R RESIDENTIAL

-----		CSR'S	.00		
				CODE	VALUE ACRES
GROSS	5.00	CURRENT			
ROADS	.38	LAND	23,250		
D.D.		BLDG			
R.R.		DWLG	78,030(1)		
MISC					
		TOTAL	101,280		
NET	4.62				

=====		=====		=====	
		YEAR	2009		
		LAND	23,250	ROAD	.38
		BLDG			
		DWLG	78,030(1)		
		TOTAL	101,280		
		NET TX			

-----		-----		-----	
DEED HOLDER:	DATE REFER	CONTRACT HOLDER:	DATE REFER	YEAR	2008
PETERSON ROBERT W	10062009 3			LAND	14,040
PETERSON PATRICIA ATSUKO				BLDG	
1774 430TH ST				DWLG	60,130(1)
SIOUX RAPIDS IA 50585				TOTAL	74,170
				NET TX	

-----		-----		-----	
FITZPATRICK WILLIAM L	09242002 2			YEAR	2007
FITZPATRICK PATRICIA K				LAND	14,040
1415 580TH ST				BLDG	
STORM LAKE IA 50588				DWLG	60,130(1)
				TOTAL	74,170
				NET TX	

-----		-----		-----	
KLINDT HAROLD K				YEAR	2007
1774 430TH ST				LAND	11,900
SIOUX RAPIDS IA				BLDG	
				DWLG	50,950(1)
				TOTAL	62,850
				NET TX	

-----		-----		-----	
REMARKS:				YEAR	2006
2 WD #022749 08/07/02 \$45,000 (D026)				LAND	11,900
3 W.D. #092896 09-16-09 \$85,500 (D000)				BLDG	
				DWLG	50,950(1)
				TOTAL	62,850
				NET TX	

-----		-----		-----	
				YEAR	2005
				LAND	11,900
				BLDG	
				DWLG	50,950(1)
				TOTAL	62,850
				NET TX	

PDF+PIN: 011+03-11-200-012 Deed: **PETERSON ROBERT W,PETERSON PATRICIA ATSI** Map Area: **LEE-RES** Checks/Tags:
 Address **1774 430TH ST** Contract: Route: **903-001-720** Lister/Date: **JH, 09/24/2008**
 (Property) CID#: **0906375** Tax Dist: **SR-R LEE** Review/Date: **DS, 10/29/2008**
 City: **SIOUX RAPIDS** DBA: Plat Page: - Entry Status: **Estimated**
RURAL/RESIDENTIAL MLS: Subdiv: **[NONE]**
 Legal: 11-93-36 S.R.-REMB. LEE LOT A IN N 1/2 NE 1/4

Land										
Land Basis	Front	Rear	Side 1	Side 2	R. Lot	SF	Acres			
Site-Excess							1.000			
Excess 1							3.620			
Sub Total						201,247.20	4.620			
Grand Total						201,247.20	4.620			

Sales				Building Permits				Values			
Date	\$ Amount	NUTC	Recording	Date	Number	Tag	\$ Amount	Reason			
09/16/2009	\$85,500	D000	092896								
08/07/2002	\$45,000	D026	#022749								

Res. Structure		1 of 1		Finish				Plumbing				Addition		Garage	
Occ. Code	101	Ttl Rooms Above #	6	Bedrooms Above #	3	Full Bath	1	Addition	1 of 1	Garage	1 of 1				
Occ. Descr.	Single-Family / Owner Occupied	Ttl Rooms Below #	0	Bedrooms Below #	0	Shower Stall Bath		Year Built	1920	Style	Det Frm				
Year Built	1920	Bsmt Fin Area #1				Toilet Room		EFA	89	W X L	0' X 0'				
EFA / EFYr	89 / 1920	Bsmt Fin Area #2				Lavatory		EFA Year	1920	Area (SF)	528				
Arch. Dsgn	N/A	Bsmt Fin Area #3				Water Closet		Style	1 Sty Frm	Year Built	1950				
Style	2 Story Frame	Foundation	C Blk			Sink		Area (SF)	256	EFA	59				
AreaSF/TLA	832 / 1,920	Exterior Walls	Vinyl			Shower Stall/Tub		Condition	Normal	EFF Year	1950				
Condition	NML	Roof	Asph / Hip			Mtl St Sh Bath									
Basement	Full	Interior Finish	Plas			Mtl Stall Shower		Bsmt (SF)		Condition	NML				
No Bsmt Flr.	0	Flooring	Vinyl			No Bathroom		NoBsmt Flr(SF)		Bsmt (SF)					
Heat	FHA - Gas	Non-base Heating		Fireplace		Wet Bar		Heat	FHA - Gas	Qtrs Over	None				
AC	Yes	Floor/Wall #	0			Whirlpool Bathroom		AC	Yes	Qtrs Over (SF)					
Attic	None	Pipeless #	0			Whirlpool Tub		Attic (SF)		Qtrs AC (SF)					
		Hand Fired (Y/N)	No			No Hot Water Tank									
		Space Heat #	0			No Plumbing				Door Opnrs					
		Appliances				Sewer & Water Only				Bsmt Stalls					
		Range Unit	Built-In Vacuums			Water Only w/Sink									
		Oven - Single	Intercom System			Hot Tub									
		Oven - Double	Bl Stereo			Bidet									
		Dishwasher				Fbgls Service Sink									
		Microwave				Urinal									
		Trash Compactor				Sauna									
		Jennair				W'Pool Bath w/Shower									
		Security System				Water Only									
						No Tub/Shower									



Bldg / Addn	Description	Units	Year					
1 of 1	101 — Single-Family / Owner Occupied							
	2 Story Frame	832						
	Base Heat: FHA - Gas							
	Add Central Air	832						
#1	Porch: 1S Frame Enclosed	80 SF						
#2	Porch: 1S Frame Open	360 SF						
1 of 1	Adtn 1 Story Frame	256 SF	1920					
	Garage: Det Frame 0' X 0'	528 SF	1950					

	Count	Ag Building Description	Units		Year						
1 of 4 P:1	1	GRANARY FR @ .90 927-Shed	10' X 18'	180 SF	1900						
2 of 4 P:3	1	SHOP FR @ .40 927-Shed	12' X 16'	192 SF	1900						
3 of 4 P:4	1	GOVT 904-Bin - Steel Grain Storage	14' X 7'	914 Bu	1900						
4 of 4 P:5	1	MTL POLE 925-Steel Utility Bldg	54' X 80'	4,320 SF	1978						

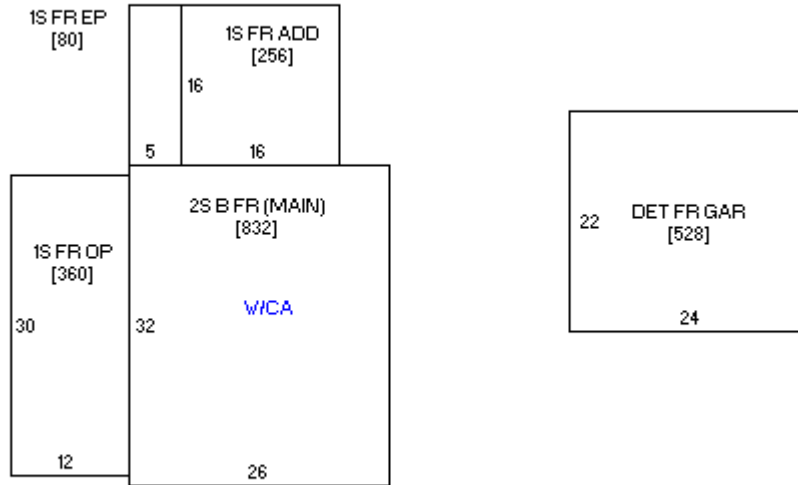



09/22/2008