

LEGAL DESCRIPTION:

CLASS:

-----		CSR'S	.00	CODE	VALUE ACRES
GROSS	CURRENT				
ROADS	LAND	9,560			
D.D.	BLDG				
R.R.	DWLG	62,950(1)			
MISC					
	TOTAL	72,510			
NET					

01-00 R RESIDENTIAL
 STORM LAKE HAYES
 MC KENNA S/D

=====		YEAR	2007		
	LAND	9,560			
	BLDG				
	DWLG	62,950(1)			
	TOTAL	72,510			
	NET TX				

DEED HOLDER:	DATE REFER	CONTRACT HOLDER:	DATE REFER	YEAR	2007
MC KENNA PATRICIA E	05092007 2			LAND	8,100
				BLDG	
				DWLG	53,350(1)
				TOTAL	61,450
				NET TX	

KLIVER RAY	1			YEAR	2006
				LAND	8,100
				BLDG	
				DWLG	53,350(1)
				TOTAL	61,450
				NET TX	

				YEAR	2005
				LAND	8,100
				BLDG	
				DWLG	53,350(1)
				TOTAL	61,450
				NET TX	

				YEAR	2004
				LAND	8,100
				BLDG	
				DWLG	53,350(1)
				TOTAL	61,450
				NET TX	

REMARKS:
 1 W.D. 58/950 02-01-93 \$50,000 (D000)
 2 W.D. #070978 04-02-07 \$77,500 (D000)

				YEAR	2003
				LAND	8,100
				BLDG	
				DWLG	53,350(1)
				TOTAL	61,450
				NET TX	780

PDF+PIN: 003+14-01-353-011 Deed: **MC KENNA PATRICIA E** Map Area: **544 MCKENNAS** Checks/Tags:
 Address: **106 MC KENNA DR** Contract: Route: **000-000-000** Lister/Date: **BRS, 01/02/1990**
 City: CID#: **0951400** Tax Dist: **STORM LAKE** Review/Date:
RURAL/RESIDENTIAL DBA: Plat Page: - Entry Status: **Inspected**
 Legal: 01-00 STORM LAKE HAYES MC KENNA S/D

Land										
Land Basis	Front	Rear	Side 1	Side 2	R. Lot	SF	Acres	Depth Factor	EFF	Qual./Land
FF Main	90.00	90.00	95.00	95.00	0.00			0.89	80.10	R-100
Sub Total						8,550.00	0.196			
Grand Total						8,550.00	0.196			

Sales				Building Permits				Values			
Date	\$ Amount	NUTC	Recording	Date	Number	Tag	\$ Amount	Reason			
04/02/2007	\$77,500	D000	070978								
02/01/1993	\$50,000	D000	058-950								
05/27/1983	\$44,700	D000									

Res. Structure		Finish				Plumbing		Addition		Garage	
Occ. Code	101	Ttl Rooms Above #	6	Bedrooms Above #	2	Full Bath	1	Addition	No Additions	Garage	1 of 1
Occ. Descr.	Single-Family / Owner Occupied	Ttl Rooms Below #	0	Bedrooms Below #	0	Shower Stall Bath		Year Built		Style	Att Brick
Year Built	1953	Bsmt Fin Area #1				Toilet Room		EFA		W X L	0' X 0'
EFA / EFYr	48 / 1953	Bsmt Fin Area #2				Lavatory		EFA Year		Area (SF)	325
Arch. Dsgn	N/A	Bsmt Fin Area #3				Water Closet		Style		Year Built	1953
Style	1 Story Brick	Foundation	C Blk			Sink		Area (SF)		EFA	48
AreaSF/TLA	1,362 / 1,362	Exterior Walls	Brk			Shower Stall/Tub		Condition		EFF Year	1953
Condition	BL NML	Roof	Asph / Hip			Mtl St Sh Bath					
Basement	None	Interior Finish	PLASTER-SOFTWOOD			Mtl Stall Shower		Bsmt (SF)		Condition	BL NML
No Bsmt Flr.	0	Flooring	Other			No Bathroom		NoBsmt Flr(SF)		Bsmt (SF)	
Heat	Yes	Non-base Heating		Fireplace		Wet Bar		Heat		Qtrs Over	None
AC	Yes	Floor/Wall #	0			Whirlpool Bathroom		AC		Qtrs Over (SF)	
Attic	None	Pipeless #	0			Whirlpool Tub		Attic (SF)		Qtrs AC (SF)	
		Hand Fired (Y/N)	No			No Hot Water Tank					
		Space Heat #	0			No Plumbing					
		Appliances				Sewer & Water Only				Door Opnrs	
		Range Unit	Intercom System			Water Only w/Sink				Bsmt Stalls	
		Oven Unit	Intercom w/Music			Hot Tub					
		Dishwasher	Built-In Stereo			Water Only					
		Microwave	Bl Stereo(SpkrsOnly)			No Tub / Shower					
		Trash Compactor	Security System			Urinal					
		Jennair				Bidet					
		B.I. Bar-B-Que				Fbgl Service Sink					
		Built-In Vacuums									



Bldg / Addn	Description	Units	Year					
1 of 1	101 — Single-Family / Owner Occupied							
	1 Story Brick	1,362						
	Adjustment for basement - None							
	Add Central Air	1,362						
#1	Porch: 1S Brick Enclosed	72 SF						
#2	Porch: Concrete Stoop	25 SF						
	Garage: Att Brick	325 SF		1953				

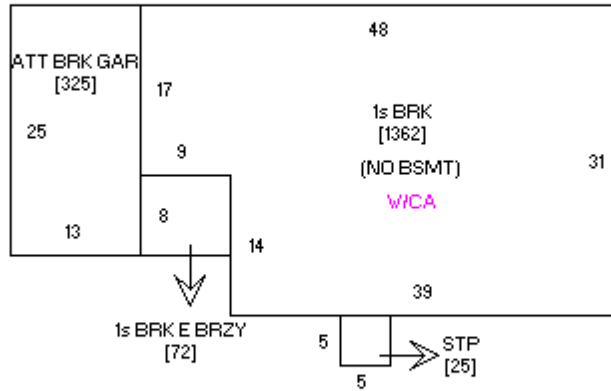

Sketch 1 of 1

