

LEGAL DESCRIPTION:

CLASS:

-----		CSR'S	.00	-----	
				CODE	VALUE ACRES
GROSS	CURRENT				
ROADS	LAND	21,630			
D.D.	BLDG				
R.R.	DWLG	213,250( 1)			
MISC					
	TOTAL	234,880			
NET					

02-08 R RESIDENTIAL  
 STORM LAKE HAYES  
 1ST PLAT BEL AIR  
 BEACH

=====		=====	=====	=====	
		YEAR	2006		
	LAND	21,630			
	BLDG				
	DWLG	213,250( 1)			
	TOTAL	234,880			
	NET TX				

DEED HOLDER:	DATE REFER	CONTRACT HOLDER:	DATE REFER	YEAR	2005
JAIMES ANIBAL	06262006 5			LAND	21,630
JAIMES ANA M				BLDG	
10041 BLANCHE CIRCLE				DWLG	213,250( 1)
BUENA PARK CA 90620				TOTAL	234,880
				NET TX	

-----	-----	-----	-----	YEAR	2004
KUHN WILLIAM P III	12152003 4			LAND	21,630
KUHN RENE K				BLDG	
140 PHEASANT DR				DWLG	213,250( 1)
STORM LAKE IA 50588				TOTAL	234,880
				NET TX	

-----	-----	-----	-----	YEAR	2003
KUHN WILLIAM P	07091998 3			NET TX	
KUHN RENE K				-----	
140 PHEASANT DR				YEAR	2003
STORM LAKE IA				LAND	21,630
				BLDG	

-----	-----	-----	-----	YEAR	2003
MC INTOSH BRENT W	2			DWLG	213,250( 1)
MC INTOSH SHERRY K				TOTAL	234,880
140 PHEASANT DR				NET TX	3,320
STORM LAKE IA				-----	

-----	-----	-----	-----	YEAR	2003
REMARKS:				LAND	20,210
				BLDG	
2 W.D. 60/422 08-26-94 \$208,500 (D000)				DWLG	199,300( 1)
3 W.D. #982353 06-30-98 \$217,500 (D000)				TOTAL	219,510
4 Q.C.D. #035140 11-04-03				NET TX	3,320
5 W.D. #061254 04-10-05 \$235,000 (D000)				-----	

-----	-----	-----	-----	YEAR	2002
				LAND	20,210
				BLDG	
				DWLG	199,300( 1)
				TOTAL	219,510
				NET TX	2,962
				-----	

**Property Record Card**

**WORKING**

**Buena Vista County Assessor**

Tue, 7/25/2006, 10:50 AM Page 1

PDF+PIN: 003+14-14-303-002

Deed: **JAIMES ANIBAL,JAIMES ANA M**

Map Area: **541 BEL AIR**

Checks/Tags:

Address: **140 PHEASANT**

Contract:

Route: **000-000-000**

Lister/Date: **TG, 02/05/1990**

City: **STORM LAKE**

CID#: **0946700**

Tax Dist: **STORM LAKE**

Review/Date:

**RURAL/RESIDENTIAL**

DBA:

Plat Page: -

Entry Status: **Inspected**

Legal:02-08 STORM LAKE HAYES 1ST PLAT BEL AIR BEACH

**Land**

Land Basis	Front	Rear	Side 1	Side 2	R. Lot	SF	Acres	Depth Factor	EFF	Qual./Land
<b>FF Main</b>	154.00	154.00	130.00	130.00	0.00			1.00	154.00	R-125
<b>Sub Total</b>						20,020.00	0.460			
<b>Grand Total</b>						20,020.00	0.460			

**Sales**

**Building Permits**

**Values**

Date	\$ Amount	NUTC	Recording	Date	Number	Tag	\$ Amount	Reason
04/10/2005	\$235,000	D000	061254					
06/30/1998	\$217,500	D000	#982353					
08/26/1994	\$208,500	D000	060-422					
07/02/1992	\$180,000	D000	058-576					

**Res. Structure** 1 of 1

**Finish**

**Plumbing**

**Addition**

**Garage**

Occ. Code	101	Ttl Rooms Above #	8	Bedrooms Above #	4	Full Bath	1	Addition	No Additions	Garage	1 of 1
Occ. Descr.	Single-Family / Owner Occupied	Ttl Rooms Below #	0	Bedrooms Below #	0	Shower Stall Bath	2	Year Built		Style	Att Frm
Year Built	1989	Bsmt Fin Area #1				Toilet Room		EFA		W X L	0' X 0'
EFA / EFYr	12 / 1989	Bsmt Fin Area #2				Lavatory	1	EFA Year		Area (SF)	651
Arch. Dsgn	N/A	Bsmt Fin Area #3				Water Closet		Style		Year Built	1989
Style	2 Story Frame	Foundation	C Blk			Sink	1	Area (SF)		EFA	12
AreaSF/TLA	1,521 / 3,386	Exterior Walls	Vinyl / Stl			Shower Stall/Tub		Condition		EFF Year	1989
Condition	Abv NML	Roof	Asph / Gable			Mtl St Sh Bath					
Basement	Full	Interior Finish	DRYWALL-DRYWALL			Mtl Stall Shower		Bsmt (SF)		Condition	Abv NML
No Bsmt Flr.	0	Flooring	CONC-SOFTWOOD-SOFTWOOD			No Bathroom		NoBsmt Flr(SF)		Bsmt (SF)	
Heat	Yes	<b>Non-base Heating</b>		<b>Fireplace</b>		Wet Bar		Heat		Qtrs Over	Frame
AC	Yes	Floor/Wall #	0	Prefab, 2 Sty	1	Whirlpool Bathroom		AC		Qtrs Over (SF)	344
Attic	None	Pipeless #	0			Whirlpool Tub		Attic (SF)		Qtrs AC (SF)	
		Hand Fired (Y/N)	No			No Hot Water Tank					
		Space Heat #	0			No Plumbing				Door Opnrs	
		<b>Appliances</b>				Sewer & Water Only				Bsmt Stalls	
		Range Unit	Intercom System			Water Only w/Sink					
		Oven Unit	Intercom w/Music			Hot Tub					
		Dishwasher	1	Built-In Stereo		Water Only					
		Microwave		BI Stereo(SpkrsOnly)		No Tub / Shower					
		Trash Compactor	Security System			Urinal					
		Jennair				Bidet					
		B.I. Bar-B-Que				Fbgl Service Sink					
		Built-In Vacuums									



Copyright © 1997-2006  
Vanguard Appraisals, Inc.

Bldg / Addn	Description	Units	Year
1 of 1	101 — Single-Family / Owner Occupied		
	2 Story Frame	1,521	
	Add Central Air	1,521	
#1	Porch: 1S Frame Open	62 SF	
	Plumbing	5	
	B.I. Appliances	1	
#1	Fireplace: Prefab, 2 Story	1	
	Garage: Att Frame	651 SF	1989

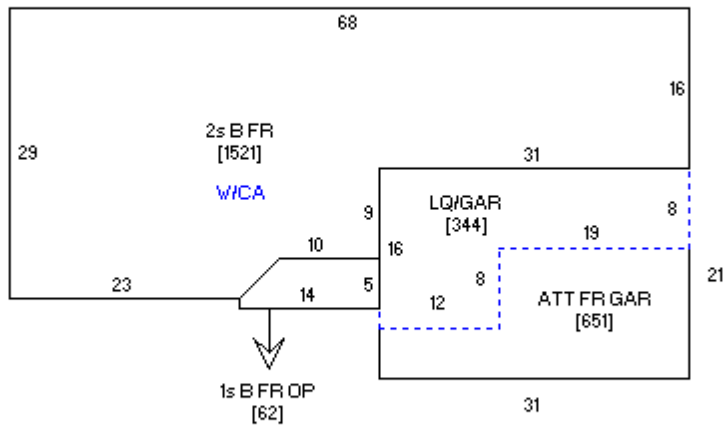

Sketch 1 of 1



Photo 1 of 1