

LEGAL DESCRIPTION:

CLASS:

12-90-37 R RESIDENTIAL
STORM LAKE HAYES
PT SW SW
(APX 389' X 823')

-----		CSR'S	.00		
				CODE	VALUE ACRES
GROSS	7.32	CURRENT			
ROADS	.38	LAND	29,330		
D.D.		BLDG			
R.R.		DWLG	294,660(2)		
MISC					
		TOTAL	323,990		
NET	6.94				

=====		=====	=====	=====	
		YEAR	2006		
		LAND	29,330	ROAD	.38
		BLDG			
		DWLG	294,660(2)		
		TOTAL	323,990		
		NET TX			

-----		-----	-----	-----	-----
DEED HOLDER:	DATE REFER	CONTRACT HOLDER:	DATE REFER	YEAR	2005
				LAND	29,330
HAM MARSHA K	07062006 3			BLDG	
				DWLG	249,690(2)
6180 120TH AVE				TOTAL	279,020
STORM LAKE IA 50588				NET TX	

-----		-----	-----	-----	-----
				YEAR	2004
				LAND	29,330
FRIESEN GARRY D	08281996 2			BLDG	
FRIESEN MARJ R				DWLG	249,690(2)
6178 120TH AVE				TOTAL	279,020
STORM LAKE IA 50588				NET TX	

-----		-----	-----	-----	-----
				YEAR	2003
				LAND	29,330
MACK SHELDON	1			BLDG	
6180 120TH AVE				DWLG	249,690(2)
P O BOX 772				TOTAL	279,020
STORM LAKE IA				NET TX	3,966

-----		-----	-----	-----	-----
				YEAR	2003
				LAND	27,410
				BLDG	
				DWLG	233,350(2)
				TOTAL	260,760
				NET TX	3,966

-----		-----	-----	-----	-----
				YEAR	2002
				LAND	27,410
				BLDG	
				DWLG	233,350(2)
				TOTAL	260,760
				NET TX	3,540

REMARKS:

1 W.D. 57/89-90 03-30-90 \$7,500

2 W.D. 61/668 07-27-96 \$225,000 (D000)

3 W.D. #061536 03-30-06 \$395,000(D000)

PDF+PIN: 003+14-12-300-004 Deed: HAM MARSHA K Map Area: 540 SL HAYES Checks/Tags:
 Address: 6180 120TH AVE Contract: Route: 000-000-000 Lister/Date: TG, 01/08/1992
 City: STORM LAKE CID#: 0925575 Tax Dist: STORM LAKE Review/Date:
RURAL/RESIDENTIAL DBA: Plat Page: Entry Status: Inspected
 Legal: 12-90-37 STORM LAKE HAYES PT SW SW (APX 389' X 823')

Land										
Land Basis	Front	Rear	Side 1	Side 2	R. Lot	SF	Acres	Depth Factor	EFF	Qual./Land
Acre X Rate						43,560.00	1.000			AC-8
Acre X Rate						43,560.00	1.000			AC-4
Acre X Rate						215,186.40	4.940			AC-3
Grand Total						302,306.40	6.940			

Sales				Building Permits				Values			
Date	\$ Amount	NUTC	Recording	Date	Number	Tag	\$ Amount	Reason			
03/30/2006	\$395,000	D000	061536								
07/27/1996	\$225,000	D000	061-668								

Res. Structure 1 of 2		Finish				Plumbing			Addition		Garage	
Occ. Code	101	Ttl Rooms Above #	0	Bedrooms Above #	0	Full Bath	1	Addition	No Additions	Garage	No garages	
Occ. Descr.	Single-Family / Owner Occupied	Ttl Rooms Below #	0	Bedrooms Below #	0	Shower Stall Bath		Year Built		Style		
Year Built	1990	Bsmt Fin Area #1				Toilet Room		EFA		W X L		
EFA / EFYr	11 / 1990	Bsmt Fin Area #2				Lavatory		EFA Year		Area (SF)		
Arch. Dsgn	N/A	Bsmt Fin Area #3				Water Closet		Style		Year Built		
Style	1 1/2 Story Frame	Foundation	None			Sink	1	Area (SF)		EFA		
AreaSF/TLA	840 / 1,628	Exterior Walls	Other			Shower Stall/Tub		Condition		EFF Year		
Condition	NML	Roof	Asph / Gable			Mtl St Sh Bath						
Basement	None	Interior Finish	DRYWALL-DRYWALL			Mtl Stall Shower		Bsmt (SF)		Condition		
No Bsmt Flr.	0	Flooring	CONCRETE-SOFTWOOD			No Bathroom		NoBsmt Flr(SF)		Bsmt (SF)		
Heat	Yes	Non-base Heating		Fireplace		Wet Bar		Heat		Qtrs Over		
AC	No	Floor/Wall #	0			Whirlpool Bathroom		AC		Qtrs Over (SF)		
Attic	None	Pipeless #	0			Whirlpool Tub		Attic (SF)		Qtrs AC (SF)		
		Hand Fired (Y/N)	No			No Hot Water Tank						
		Space Heat #	0			No Plumbing				Door Opnrs		
		Appliances				Sewer & Water Only				Bsmt Stalls		
		Range Unit	Intercom System			Water Only w/Sink						
		Oven Unit	Intercom w/Music			Hot Tub						
		Dishwasher	Built-In Stereo			Water Only						
		Microwave	BI Stereo(SpkrsOnly)			No Tub / Shower						
		Trash Compactor	Security System			Urinal						
		Jennair				Bidet						
		B.I. Bar-B-Que				FbglS Service Sink						
		Built-In Vacuums										

Bldg / Addn	Description	Units	Year						
1 of 2	101 — Single-Family / Owner Occupied								
	1 1/2 Story Frame	840							
	Adjustment for basement - None								
#1	Porch: 1S Frame Enclosed	1,080 SF							
	Frame Quarters Over Adjustment	200 SF							
	Deck #1: Wood Deck-Med	56 SF							
	Plumbing	2							

Res. Structure		2 of 2		Finish		Plumbing		Addition		Garage	
Occ. Code	101	Ttl Rooms Above #	8	Bedrooms Above #	4	Full Bath	3	Addition	1 of 2	Garage	1 of 1
Occ. Descr.	Single-Family / Owner Occupied	Ttl Rooms Below #	0	Bedrooms Below #	0	Shower Stall Bath		Year Built	1992	Style	Att Frm
Year Built	1992	Bsmt Fin Area #1	2000	Table		Toilet Room		EFA	9	W X L	0' X 0'
EFA / EFYr	9 / 1992	Bsmt Fin Area #2				Lavatory		EFA Year	1992	Area (SF)	806
Arch. Dsgn	N/A	Bsmt Fin Area #3				Water Closet		Style	2 Sty Frm	Year Built	1992
Style	1 Story Frame	Foundation	C Blk			Sink		Area (SF)	624	EFA	9
AreaSF/TLA	1,579 / 3,589	Exterior Walls	Vinyl / Stl			Shower Stall/Tub	1	Condition	Above Normal	EFF Year	1992
Condition	Abv NML	Roof	Asph / Gable			Mtl St Sh Bath					
Basement	Full	Interior Finish	DRYWALL/HARDWOOD			Mtl Stall Shower		Bsmt (SF)	624	Condition	Abv NML
No Bsmt Flr.	0	Flooring	Carp / Ceramic / Hwd			No Bathroom		NoBsmt Flr(SF)		Bsmt (SF)	
Heat	Yes	Non-base Heating		Fireplace		Wet Bar		Heat	Yes	Qtrs Over	None
AC	Yes	Floor/Wall #	0	Prefab, 1 Sty	1	Whirlpool Bathroom		AC	Yes	Qtrs Over (SF)	
Attic	1/4 Finished, 395SF	Pipeless #	0			Whirlpool Tub		Attic (SF)		Qtrs AC (SF)	
		Hand Fired (Y/N)	No			No Hot Water Tank		See other pages for more additions.			
		Space Heat #	0			No Plumbing				Door Opnrs	
		Appliances				Sewer & Water Only				Bsmt Stalls	
		Range Unit		Intercom System		Water Only w/Sink					
		Oven Unit		Intercom w/Music		Hot Tub					
		Dishwasher	1	Built-In Stereo		Water Only					
		Microwave		BI Stereo(SpkrsOnly)		No Tub / Shower					
		Trash Compactor		Security System		Urinal					
		Jennair				Bidet					
		B.I. Bar-B-Que				FbglS Service Sink					
		Built-In Vacuums									



Bldg / Adtn	Description	Units	Year					
2 of 2	101 — Single-Family / Owner Occupied							
	1 Story Frame	1,579						
#1	Bsmt Fin - Rec. Room (Single) (Avg)	2,000 Tbl						
	Add Central Air	1,579						
	Add 1/4 Finished attic	395						
#1	Porch: Frame 3 Seasons	140 SF						
	Deck #1: Wood Deck-Med	117 SF						
	Deck #2: Wood Deck-Med	506 SF						
	Veneer #1 1/2 Story Brick	56.0 LF						
	Plumbing	4						
	B.I. Appliances	1						
#1	Fireplace: Prefab, 1 Story	1						
	Garage: Att Frame	806 SF	1992					
1 of 2	Adtn 2 Story Frame	624 SF	1992					
2 of 2	Adtn 1 Story Frame	367 SF	1992					

	Count	Ag Building Description	Units		Year								
1 of 1 P:1	1	MTL POLE 925—Steel Utility Bldg	30' X 60'	1,800 SF		1991							

	Description	Units	Year
P:0	Yrd 1 — (NV) CONC PAVING		1990

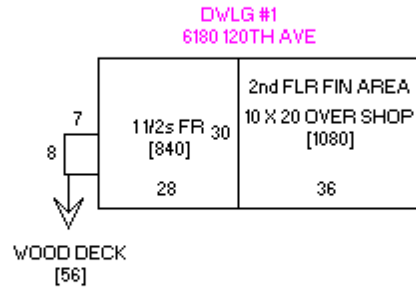

Sketch 1 of 2

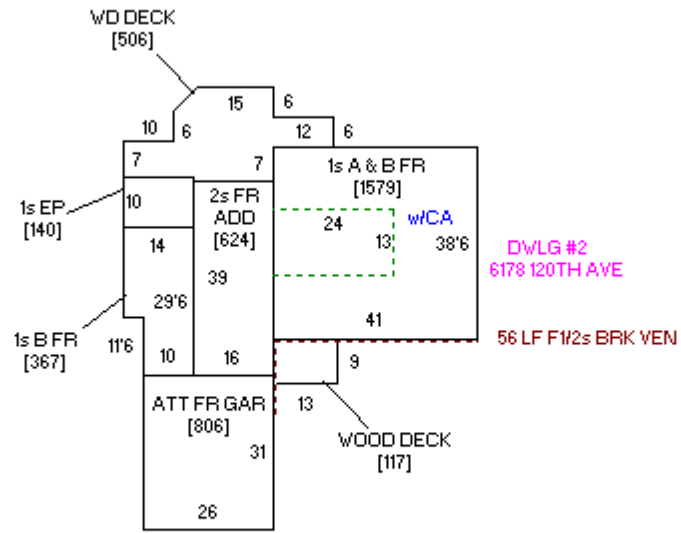

Sketch 2 of 2

