

Pin: 06-12-400-009
Sale Date: 10/02/06
Sale Price: \$105,470
Acres: 8.51 Net
Classification: Change in use from
Ag to Rural Residential

06-12-400-009

#10155.30

R-Res

Photo 1 of 2



06-12-400-009 #10155.30

R-Res

Photo 1 of 2



NOV 2 2006

LEGAL DESCRIPTION:

CLASS:

12-92-37
S.R.-REMB. SCOTT
LOT A IN E 1/2 SE

A AGRICULTURE

| ----- | | CSR'S | 622.10 | ----- | |
|-------|------|---------|------------|-------|-------------|
| | | | | CODE | VALUE ACRES |
| GROSS | 9.35 | CURRENT | | | |
| ROADS | .84 | LAND | 5,440 | | |
| D.D. | | BLDG | 8,630(6) | | |
| R.R. | | DWLG | 40,710(1) | | |
| MISC | | | | | |
| | | TOTAL | 54,780 | | |
| NET | 8.51 | | | | |

| ===== | | ===== | ===== | ===== | |
|-------|--|--------|------------|--------|---|
| | | YEAR | 2006 | REFER: | 1 |
| | | LAND | 5,440 | | |
| | | BLDG | 8,630(6) | | |
| | | DWLG | 40,710(1) | | |
| | | TOTAL | 54,780 | | |
| | | NET TX | | | |

DEED HOLDER:
BINDER TRUCKING INC
1935 470TH ST
SIOUX RAPIDS IA 50585

DATE REFER
11022006 2

CONTRACT HOLDER:

DATE REFER
YEAR
LAND
BLDG
DWLG
TOTAL
NET TX

HOOVER ANNE E
P O BOX 1126
STORM LAKE IA 50588

YEAR
LAND
BLDG
DWLG
TOTAL
NET TX

REMARKS:

1 06)SPLIT FROM -002 & -005 (11/02/06)
2 WD #062836 10/02/06 \$105,470 (D026)

YEAR
LAND
BLDG
DWLG
TOTAL
NET TX

YEAR
LAND
BLDG
DWLG
TOTAL
NET TX

PDF+PIN: 003+06-12-400-009 Deed: **BINDER TRUCKING INC** Map Area: **440 SR-R SCOTT** Checks/Tags:
 Address: **4971 HWY 71** Contract: Route: **000-000-000** Lister/Date: **CVH, 12/03/1986**
 City: **REMBRANDT** CID#: **1015575** Tax Dist: **S.R.-REMB.** Review/Date:
RURAL/RESIDENTIAL DBA: Plat Page: Entry Status: **Inspected**
 Legal: 12-92-37 S.R.-REMB. SCOTT LOT A IN E 1/2 SE

| Land | | | | | | | | | | |
|---------------------|-------|------|--------|--------|--------|------------|-------|--------------|-----|------------|
| Land Basis | Front | Rear | Side 1 | Side 2 | R. Lot | SF | Acres | Depth Factor | EFF | Qual./Land |
| Acres X Rate | | | | | | 43,560.00 | 1.000 | | | AC-5 |
| Acres X Rate | | | | | | 43,560.00 | 1.000 | | | AC-4 |
| Acres X Rate | | | | | | 283,575.60 | 6.510 | | | AC-1 |
| Grand Total | | | | | | 370,695.60 | 8.510 | | | |

| Sales | | | | Building Permits | | | | Values | | | |
|------------|-----------|------|-----------|------------------|--------|-----|-----------|--------|--|--|--|
| Date | \$ Amount | NUTC | Recording | Date | Number | Tag | \$ Amount | Reason | | | |
| 10/02/2006 | \$105,470 | D026 | 062836 | | | | | | | | |

| Res. Structure 1 of 1 | | Finish | | | | Plumbing | | | Addition | | Garage | |
|-----------------------|--------------------------------|-------------------------|-------------------------|------------------|---|--------------------|---|-------------------------------------|--------------|----------------|------------|--|
| Occ. Code | 101 | Ttl Rooms Above # | 44 | Bedrooms Above # | 0 | Full Bath | 1 | Addition | 1 of 2 | Garage | No garages | |
| Occ. Descr. | Single-Family / Owner Occupied | Ttl Rooms Below # | 0 | Bedrooms Below # | 0 | Shower Stall Bath | | Year Built | 1900 | Style | | |
| Year Built | 1900 | Bsmt Fin Area #1 | | | | Toilet Room | 1 | EFA | 101 | W X L | | |
| EFA / EFYr | 101 / 1900 | Bsmt Fin Area #2 | | | | Lavatory | | EFA Year | 1900 | Area (SF) | | |
| Arch. Dsgn | N/A | Bsmt Fin Area #3 | | | | Water Closet | | Style | 1 Sty Frm | Year Built | | |
| Style | 2 Story Frame | Foundation | Strn | | | Sink | | Area (SF) | 72 | EFA | | |
| AreaSF/TLA | 720 / 1,560 | Exterior Walls | Other | | | Shower Stall/Tub | | Condition | Above Normal | EFF Year | | |
| Condition | Abv NML | Roof | Wd / Gable | | | Mtl St Sh Bath | | | | | | |
| Basement | Full | Interior Finish | PLASTER/SOFT-PLAST/SOFT | | | Mtl Stall Shower | | Bsmt (SF) | | Condition | | |
| No Bsmt Flr. | 0 | Flooring | None | | | No Bathroom | | NoBsmt Flr(SF) | | Bsmt (SF) | | |
| Heat | Yes | Non-base Heating | | Fireplace | | Wet Bar | | Heat | Yes | Qtrs Over | | |
| AC | Yes | Floor/Wall # | 0 | | | Whirlpool Bathroom | | AC | Yes | Qtrs Over (SF) | | |
| Attic | None | Pipeless # | 0 | | | Whirlpool Tub | | Attic (SF) | | Qtrs AC (SF) | | |
| | | Hand Fired (Y/N) | No | | | No Hot Water Tank | | See other pages for more additions. | | | | |
| | | Space Heat # | 0 | | | No Plumbing | | | | | | |
| | | Appliances | | | | Sewer & Water Only | | | | Door Opnrs | | |
| | | Range Unit | Intercom System | | | Water Only w/Sink | | | | Bsmt Stalls | | |
| | | Oven Unit | Intercom w/Music | | | Hot Tub | | | | | | |
| | | Dishwasher | Built-In Stereo | | | Water Only | | | | | | |
| | | Microwave | Bl Stereo(SpkrsOnly) | | | No Tub / Shower | | | | | | |
| | | Trash Compactor | Security System | | | Urinal | | | | | | |
| | | Jennair | | | | Bidet | | | | | | |
| | | B.I. Bar-B-Que | | | | Fbgl Service Sink | | | | | | |
| | | Built-In Vacuums | | | | | | | | | | |



| Bldg / Addn | Description | Units | Year | | | | | |
|-------------|--------------------------------------|-------|------|--|--|--|--|--|
| 1 of 1 | 101 — Single-Family / Owner Occupied | | | | | | | |
| | 2 Story Frame | 720 | | | | | | |
| | Add Central Air | 720 | | | | | | |
| #1 | Porch: 1S Frame Open | 30 SF | | | | | | |
| | Plumbing | 2 | | | | | | |
| 1 of 2 | Adtn 1 Story Frame | 72 SF | 1900 | | | | | |
| 2 of 2 | Adtn 1 Story Frame | 48 SF | 1900 | | | | | |

| | Count | Ag Building Description | Units | Year | | | | | | |
|---------------|-------|--|--------------------|------|--|--|--|--|--|--|
| 1 of 5 P:2 | 1 | LOFT FR @ .90 906—Barn - Flat | 34' X 48' 1,632 SF | 1900 | | | | | | |
| 2 of 5 P:3 | 1 | STORAGE 904—Bin - Steel Grain Storage | 27' X 18' 8,282 Bu | 1978 | | | | | | |
| 3 of 5 P:4 | 1 | MTL POLE 925—Steel Utility Bldg | 22' X 48' 1,056 SF | 1985 | | | | | | |
| 4 of 5 P:5 | 1 | MACH TILE @ .90 927—Shed | 20' X 60' 1,200 SF | 1900 | | | | | | |
| 5 of 5 P:6 | 1 | STG FR @ .90 927—Shed | 12' X 24' 288 SF | 1900 | | | | | | |

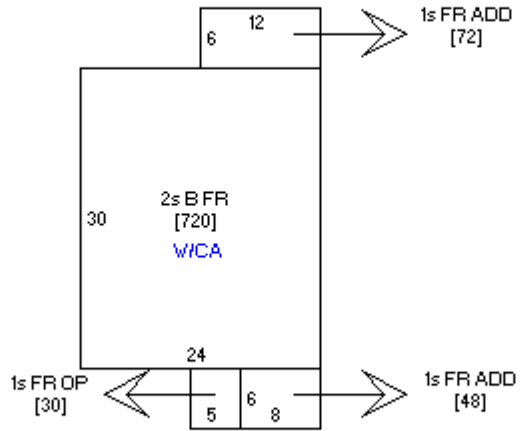

Sketch 1 of 1

