

Pin: 03-18-100-005
Sale Date: 08/17/06
Sale Price: \$60,000
Acres: 4.03 Net
Classification: Change in use
from Ag to Rural Residential

03-18-100-005

#9097.25

R-Res



LEGAL DESCRIPTION:

CLASS:

18-93-36 A AGRICULTURE
S.R.-REMB. LEE
PT. E 1/2 NW FR 1/4

-----		CSR'S	315.00		
				CODE	VALUE ACRES
GROSS	4.34	CURRENT			
ROADS	.31	LAND	2,760		
D.D.		BLDG	2,360(5)		
R.R.		DWLG	31,680(1)		
MISC					
		TOTAL	36,800		
NET	4.03				

=====		=====		=====	
		YEAR	2006		
		LAND	2,760	ROAD	.31
		BLDG	2,360(5)		
		DWLG	31,680(1)		
		TOTAL	36,800		
		NET TX			

-----		-----		-----	
DEED HOLDER:	DATE REFER	CONTRACT HOLDER:	DATE REFER	YEAR	2005
				LAND	2,760
ORWIG STEVEN ALAN	10262006 3			BLDG	2,360(5)
ORWIG BECKY JEAN				DWLG	31,680(1)
5373 250TH AVE				TOTAL	36,800
ALBERT CITY IA 50510				NET TX	

-----		-----		-----	
				YEAR	2004
				LAND	2,760
1342 440TH ST				BLDG	2,360(5)
SIOUX RAPIDS IA 50585				DWLG	31,680(1)
				TOTAL	36,800
				NET TX	

-----		-----		-----	
				YEAR	2003
				LAND	2,760
				BLDG	2,360(5)
				DWLG	31,680(1)
				TOTAL	36,800
				NET TX	432

-----		-----		-----	
REMARKS:				YEAR	2003
				LAND	2,760
				BLDG	2,360(5)
1 W.D. 52/849-50 06-23-83 \$36,000				DWLG	29,610(1)
2 AFFIDAVIT #062689 08-17-06				TOTAL	34,730
3 W.D. #062690 08-17-06 \$60,000 (D000)				NET TX	432

-----		-----		-----	
				YEAR	2002
				LAND	4,080
				BLDG	2,360(5)
				DWLG	29,610(1)
				TOTAL	36,050
				NET TX	390

PDF+PIN: 003+03-18-100-005 Deed: **ORWIG STEVEN ALAN,ORWIG BECKY JEAN** Map Area: **470 SR-R LEE** Checks/Tags:
 Address: **1342 440TH ST** Contract: Tax Dist: **S.R.-REMB.** Route: **000-000-000** Lister/Date: **CVH, 11/21/1986**
 City: CID#: **0909725** DBA: Plat Page: - Review/Date:
RURAL/RESIDENTIAL Legal: 18-93-36 S.R.-REMB. LEE PT. E 1/2 NW FR 1/4 Entry Status: **Inspected**

Land										
Land Basis	Front	Rear	Side 1	Side 2	R. Lot	SF	Acres	Depth Factor	EFF	Qual./Land
Acres X Rate						43,560.00	1.000			AC-4
Acres X Rate						131,986.80	3.030			AC-1
Grand Total						175,546.80	4.030			

Sales				Building Permits				Values			
Date	\$ Amount	NUTC	Recording	Date	Number	Tag	\$ Amount	Reason			
08/17/2006	\$60,000	D015	062690								

Res. Structure		Finish				Plumbing		Addition		Garage	
Occ. Code	101	Ttl Rooms Above #	34	Bedrooms Above #	0	Full Bath	2	Addition	No Additions	Garage	1 of 1
Occ. Descr.	Single-Family / Owner Occupied	Ttl Rooms Below #	0	Bedrooms Below #	0	Shower Stall Bath		Year Built		Style	Det Frm
Year Built	1900	Bsmt Fin Area #1				Toilet Room		EFA		W X L	14' X 24'
EFA / EFYr	101 / 1900	Bsmt Fin Area #2				Lavatory		EFA Year		Area (SF)	336
Arch. Dsgn	N/A	Bsmt Fin Area #3				Water Closet		Style		Year Built	1900
Style	2 Story Frame	Foundation	Str			Sink		Area (SF)		EFA	101
AreaSF/TLA	860 / 1,720	Exterior Walls	Other			Shower Stall/Tub		Condition		EFF Year	1900
Condition	NML	Roof	Asph / Hip			Mtl St Sh Bath					
Basement	1/2	Interior Finish	PLASTER/SOFT-PLAST/SOFT			Mtl Stall Shower		Bsmt (SF)		Condition	NML
No Bsmt Flr.	0	Flooring	CONC-SOFTWOOD-SOFTWOOD			No Bathroom		NoBsmt Flr(SF)		Bsmt (SF)	
Heat	Yes	Non-base Heating		Fireplace		Wet Bar		Heat		Qtrs Over	None
AC	No	Floor/Wall #	0			Whirlpool Bathroom		AC		Qtrs Over (SF)	
Attic	Floor & Stairs	Pipeless #	0			Whirlpool Tub		Attic (SF)		Qtrs AC (SF)	
		Hand Fired (Y/N)	No			No Hot Water Tank					
		Space Heat #	0			No Plumbing					
		Appliances				Sewer & Water Only				Door Opnrs	
		Range Unit		Intercom System		Water Only w/Sink				Bsmt Stalls	
		Oven Unit		Intercom w/Music		Hot Tub					
		Dishwasher		Built-In Stereo		Water Only					
		Microwave		BI Stereo(SpkrsOnly)		No Tub / Shower					
		Trash Compactor		Security System		Urinal					
		Jennair				Bidet					
		B.I. Bar-B-Que				Fbgl Service Sink					
		Built-In Vacuums									

Bldg / Addn	Description	Units	Year						
1 of 1	101 — Single-Family / Owner Occupied								
	2 Story Frame	860							
	Adjustment for basement - 1/2								
	Add Floor & Stairs attic								
#1	Porch: 1S Frame Open	40 SF							
#2	Porch: 1S Frame Enclosed	84 SF							
	Plumbing	2							
	Garage: Det Frame	14' X 24'	336 SF		1900				

	Count	Ag Building Description	Units	Year						
1 of 5 P:1	1	HEN HSE FR @ .40 927—Shed	24' X 24' 576 SF	1900						
2 of 5 P:2	1	OP FR @ .40 927—Shed	20' X 42' 840 SF	1900						
3 of 5 P:4	1	DBL OHB FR @ .90 926—Crib	27' X 32' 864 SF	1900						
4 of 5 P:5	1	FEED FR @ .40 907—Barn - Feed and Livestocl	48' X 50' 2,400 SF	1900						
5 of 5 P:6	1	STG FR @ .40 927—Shed	10' X 12' 120 SF	1900						

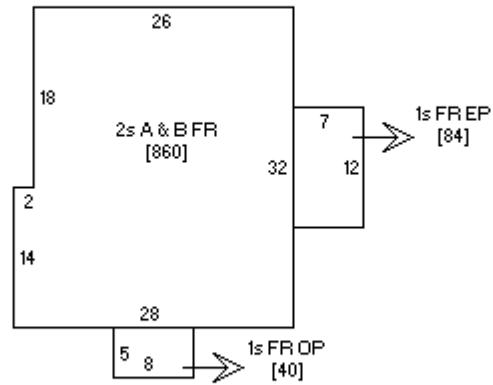

Sketch 1 of 1