

PDF+PIN: 003+10-30-351-007 Deed: HACH TARA L Map Area: 261 LAKE CREEK Checks/Tags:
 Address: 717 HWY 7 Contract: Route: 000-000-000 Lister/Date: KMC, 06/18/1986
 City: ALTA CID#: 0981200 Tax Dist: ALTA Review/Date: ---, 09/29/1994
RURAL/RESIDENTIAL DBA: Plat Page: - Entry Status: Inspected
 Legal: 30-91-37 ALTA WASHINGTON AUD S/D SW FR 1/4 EAST PT OF LOT 35

Land										
Land Basis	Front	Rear	Side 1	Side 2	R. Lot	SF	Acres	Depth Factor	EFF	Qual./Land
FF Main	205.00	193.60	232.00	182.00	0.00			1.13	227.36	R-270
Sub Total						41,255.10	0.947			
Grand Total						41,255.10	0.947			

Sales				Building Permits				Values			
Date	\$ Amount	NUTC	Recording	Date	Number	\$ Amount	Reason				
11/8/2004	\$82,000	D000	#044104								

Res. Structure 1 of 1		Finish		Plumbing		Addition		Garage	
Occ. Code	101	Ttl Rooms Above #	7	Bedrooms Above #	4	Full Bath	1	Addition	1 of 2
Occ. Descr.	Single-Family / Owner Occupied	Ttl Rooms Below #	0	Bedrooms Below #	0	Shower Stall Bath		Year Built	1906
Year Built	1906	Bsmt Fin Area #1				Toilet Room	1	EFA	95
EFA / EFYr	95 / 1906	Bsmt Fin Area #2				Lavatory		EFA Year	1906
Arch. Dsgn	N/A	Bsmt Fin Area #3				Water Closet	1	Style	1 Story Frm
Style	1 Story Frame	Foundation	C Blk / Strn			Sink		Area (SF)	168
AreaSF/TLA	564 / 1,170	Exterior Walls	Stl			Shower Stall/Tub		Condition	Very Good
Condition	Very Good	Roof	Asph / Gable			Mtl St Sh Bath		EFF Year	1954
Basement	Full	Interior Finish	PLASTER/SOFT-PLAST/SOFT			Mtl Stall Shower		Bsmt (SF)	
No Bsmt Flr.	0	Flooring	CONC-SOFTWOOD-SOFTWOOD			No Bathroom		NoBsmt Flr(SF)	
Heat	Yes	Non-base Heating		Fireplace		Wet Bar		Heat	Yes
AC	Yes	Floor/Wall #	0			Whirlpool Bathroom		AC	No
Attic	Fully Finished	Pipeless #	0			Whirlpool Tub		Attic (SF)	
		Hand Fired (Y/N)	No			No Hot Water Tank		See other pages for more additions.	
		Space Heat #	0			No Plumbing		Qtrs Over	None
		Appliances				Sewer & Water Only		Qtrs Over (SF)	
		Range Unit	Intercom System			Water Only w/Sink		Qtrs AC (SF)	
		Oven Unit	Intercom w/Music			Hot Tub		Door Opnrs	1
		Dishwasher	1	Built-In Stereo		Water Only		Bsmt Stalls	
		Microwave		Bl Stereo(SpkrsOnly)		No Tub / Shower			
		Trash Compactor		Security System		Urinal			
		Jennair				Bidet			
		B.I. Bar-B-Que				FbglS Service Sink			
		Built-In Vacuums							

Bldg / Addn	Description	Units	Year					
1 of 1	101 — Single-Family / Owner Occupied							
	1 Story Frame	564						
	Add Central Air	564						
	Add Fully Finished attic							
#1	Porch: 1S Frame Enclosed	144 SF						
	Deck #1: Wood Deck-Med	50 SF						
	Deck #2: Brick/Blk Patio-Med	294 SF						
	Plumbing	2						
	B.I. Appliances	1						
1 of 2 Adtn	1 Story Frm	168 SF	1906					
2 of 2 Adtn	1 Story Frm	128 SF	1906					
	Garage: Det Frame 24' X 48'	1,152 SF	1954					

	Description	Units	Year
Plot:1	Yrd 1— BEAUTY SH FIN(10X24) 240 Square Feet, 0 High		1973
Plot:2	Yrd 1— Sheds 1,872 SF Frame, Low Pricing		1981

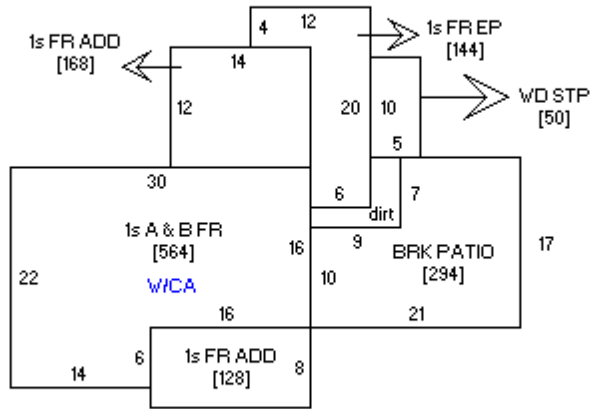

Sketch 1 of 1

Photo 2 of 2



Photo 1 of 2